

March 2005

Mousehole Crushes Mans Leg

A crew was attempting to lower the upper half of the mousehole into place when the hook came loose. The upper section of the mousehole, weighing about 600 lbs, fell down onto an employee and crushed his right lower leg.

How it happened

Gusting winds caused the top of the mousehole to move toward the V-door. This caused the bottom of the mousehole to rest on the beam that supports the rotary beams.

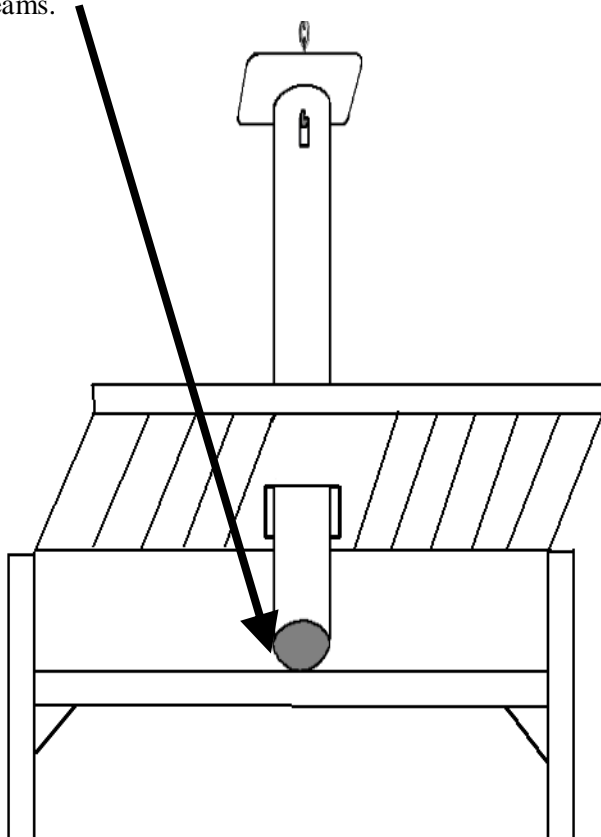

The hook then came loose. The mousehole section slipped off the beam, angled toward the man below and pinned him against the sub, crushing his lower right leg.

The Right Way

Always double wrap your line around the mousehole. When it reaches about 2 feet from seating into the lower half of the mousehole, use the catline to lift it off of the air hoist line. Remove the air hoist line and lower it into place.

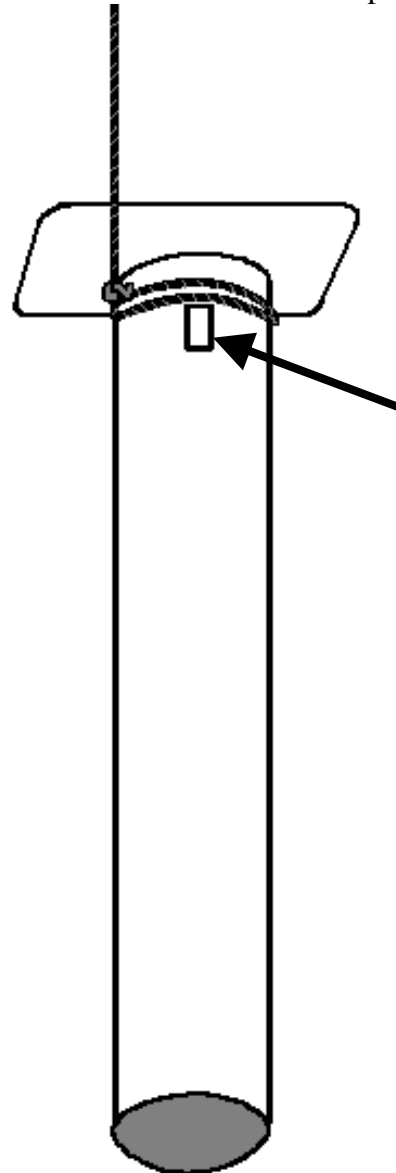

Use the reverse order of this method to take the mousehole out of place when rigging down.

Never rely on simply hooking the slot in the mousehole. An unsecured connection like that is obviously subject to the wind.

Another suggestion is to weld a section of conductor pipe under the sub that would guide the pipe past the beam and restrict its ability to achieve that angle.